

M100 Naja 3D Electronic Measuring

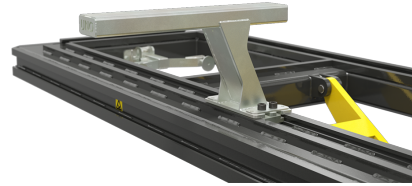
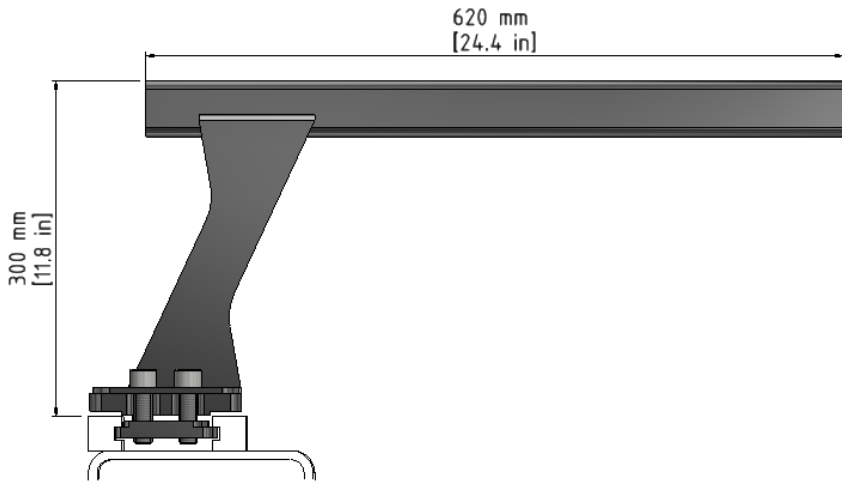

The UnoLiner M100 NAJA 3D Electronic Collision Repair Measuring System. The most advanced, accurate, and user-friendly measuring solution in the collision repair industry. Including easy to use software ensuring faultless measurement readings using the green and red symbols. (green for good and red for faulty). The UnoLiner Naja 3D Collision Repair Measuring System is supremely flexible. Perfect on all UnoLiner Collision Repair Bench Frames. Also stand alone using the UnoLiner **M110 High Support**. Approved by all major manufacturers a.o. Daimler Group, General Motors, BMW, Ford, Aston Martin, McLaren and Mercedes for autobody and chassis measuring. UnoLiners partnership with Celette, reinforces a shared commitment to delivering best-in-class diagnostic equipment and repair systems.

Features

- ✓ Worlds largest vehicle database
- ✓ Approved by all major automobile manufacturers
- ✓ Measurement of any vehicle in real time
- ✓ Bluetooth wireless connection.
- ✓ Optional M110 High Support for stand alone use

Technical data

Max measuring length	700	cm
Max measuring width	200	cm
Max measuring height	100	cm
Measuring sensor head	5	Pce
Measuring accuracy	+ / - 0.7	mm

